

Performance Features

- Conversion gain: 15dB
- Mirror rejection: 23dBc
- 2 LO to RF isolation: 45dB
- Noise factor: 2.3dB
- Input IP3: -1dBm
- Package size: 4mm*4mm 24-pin QFN

Overview

The CWDC264SP4 is a GaAs MMIC I/Q downconverter that integrates a double balanced mixer, a fundamental quadrature amplifier, and an RF self-biasing low-noise amplifier. This downconverter is mainly used in typical commercial communication systems.

Typical Applications

- Point-to-Point Communication
- Radar, satellite communications
- Point-to-Multiple Communications

Functional Block Diagram

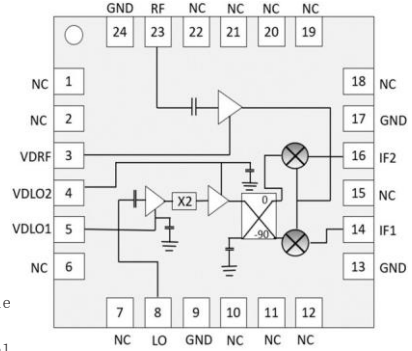

Electrical performance table (TA=+25°C, IF=1000MHz, LO=+6dBm, VDRF/VDLO 1/VDLO 2=3.5V)

Parameter Name	Description	Minimum value	Typical values	Maximum value	Unit
Frequency range	RF Port	17.5~21.5			GHz
Frequency range	LO Port	7.25~12.5			GHz
Frequency range	IF Port	DC~3.5			GHz
Conversion gain			15		dB
Noise factor			2.3		dB
Mirror Suppression			23		dBc
Input 1dB compression point			-8		dBm
Isolation degree	2LO to RF port		-45		dB
	2LO to IF port		-13		dB
Enter IP3			-1		dBm
Operating current			160	200	mA

Test Curve

Variable gain vs. local oscillation power (USB IF=1GHz)

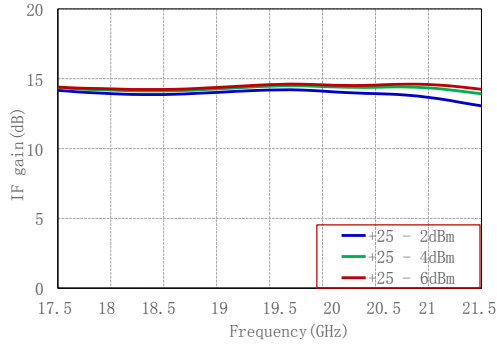

Variable gain vs. temperature (USB IF=1GHz)

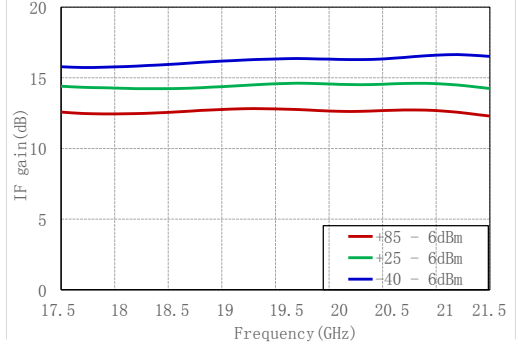

Variable gain vs. local oscillation power (USB IF=3.3GHz)

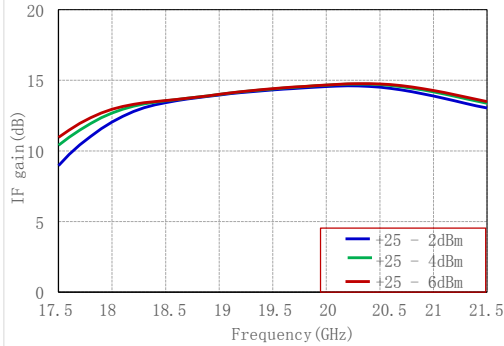

Variable gain VS temperature (USB IF=3.3GHz)

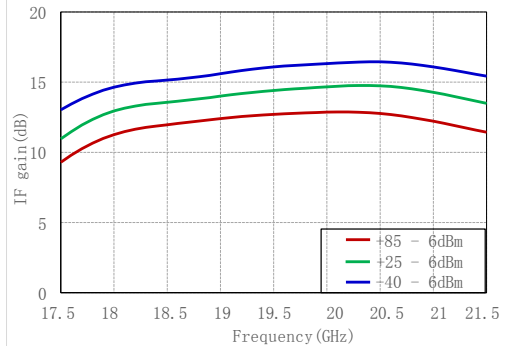

Variable frequency gain vs. local oscillation power (LSB IF=1GHz)

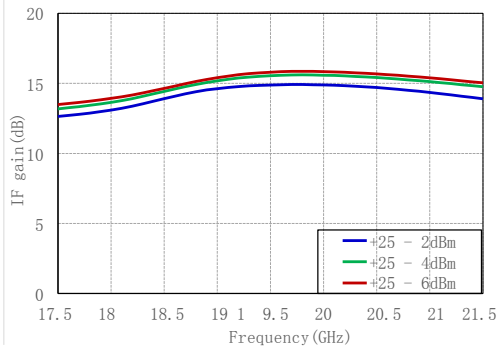

Variable frequency gain vs. temperature (LSB IF=1GHz)

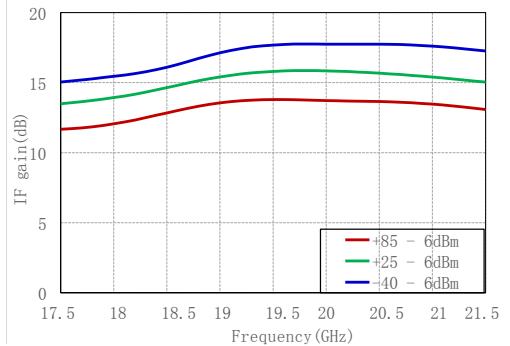

CWDC

Lower Variable Frequency Series

Test Curve

Variable frequency gain vs. local oscillation power (LSB IF=3.3GHz)

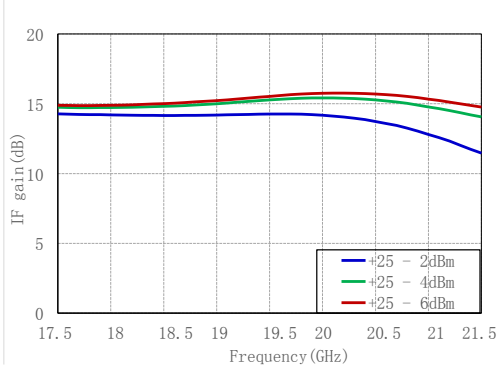

Variable gain vs. temperature (LSB IF=3.3GHz)

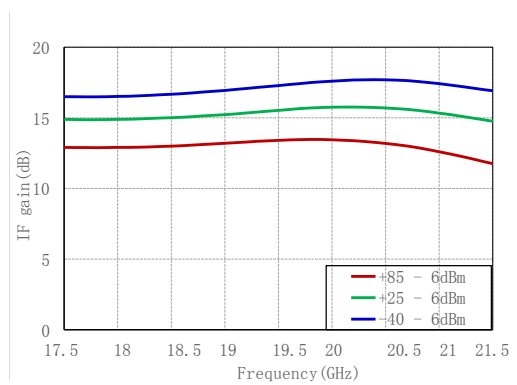

Mirror rejection vs. local oscillation power (USB IF=1GHz)

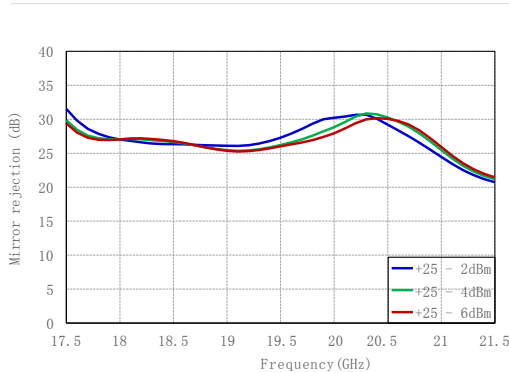

Mirror rejection vs. temperature (USB IF=1GHz)

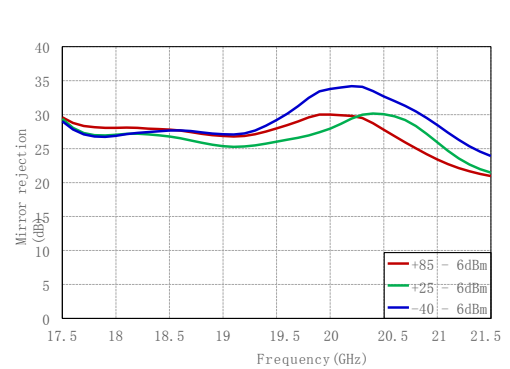

Mirror rejection vs. local oscillation power (USB IF=3.3GHz)

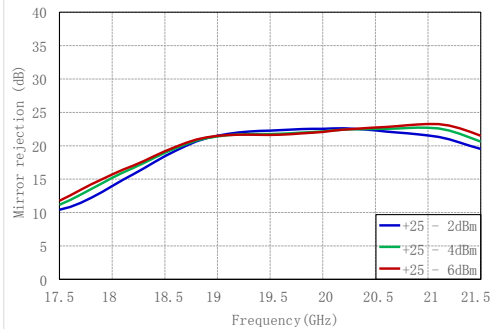

Mirror rejection vs. temperature (USB IF=3.3GHz)

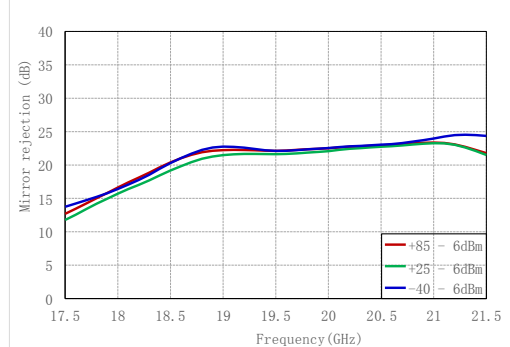

Test Curve

Mirror rejection vs. local oscillation power (LSB IF=1GHz)

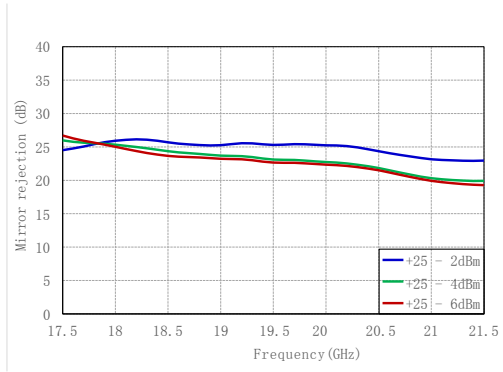

Mirror rejection VS temperature (LSB IF=1GHz)

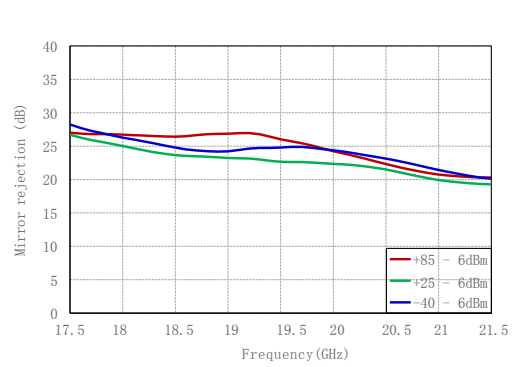

Mirror rejection vs. local oscillation power (LSB IF=3.3GHz)

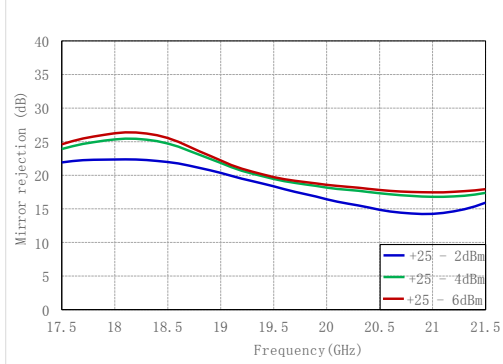

Mirror rejection vs. temperature (LSB IF=3.3GHz)

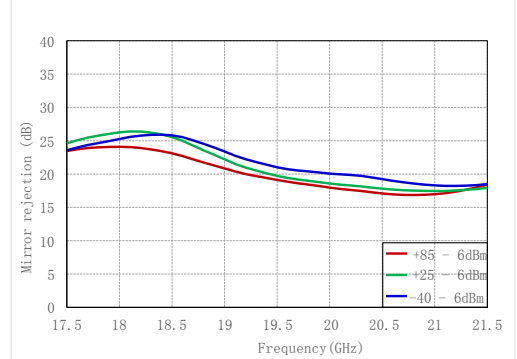

Isolation vs. frequency (RF-IF1, RF-IF2)

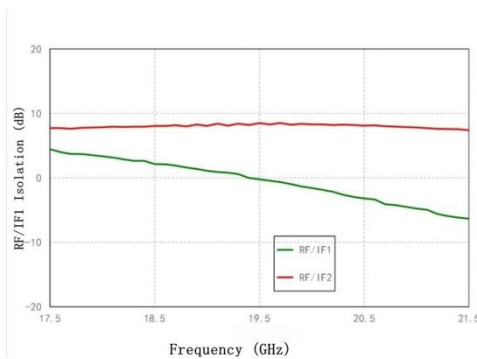

Isolation vs. temperature (2LO-IF)

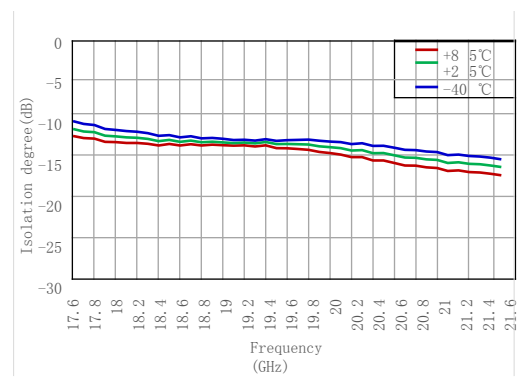

Test Curve

Isolation vs. temperature (2LO-RF)

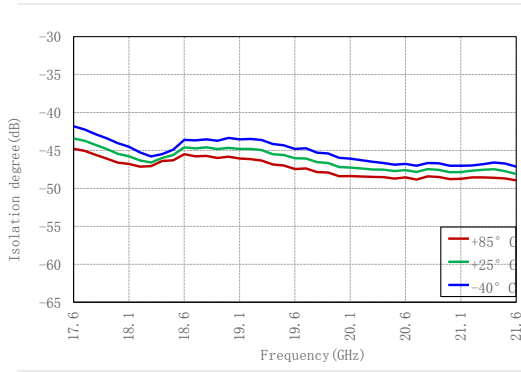

Return loss of local oscillation VS frequency (LO power is 6dBm)

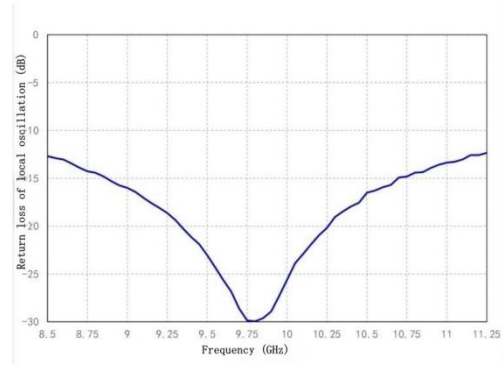

RF return loss vs. local oscillation power

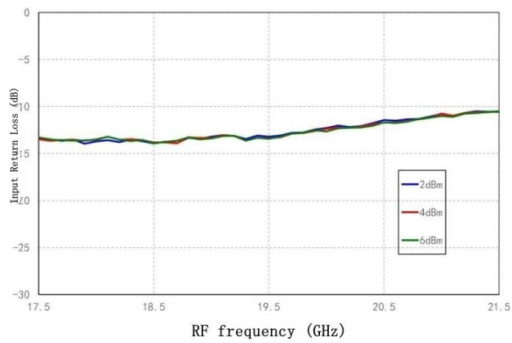

IF return loss vs. RF frequency (USB@LO=8.5GHz power is 6dBm)

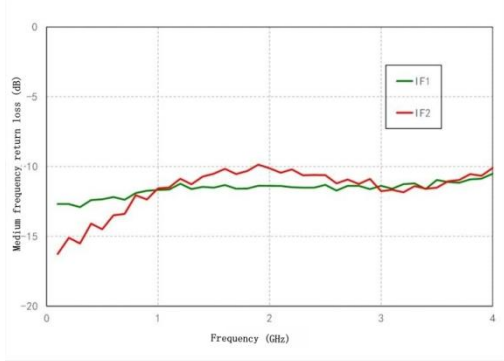

Noise factor vs. temperature (LSB@LO=10.5 GHz power is 6dBm)

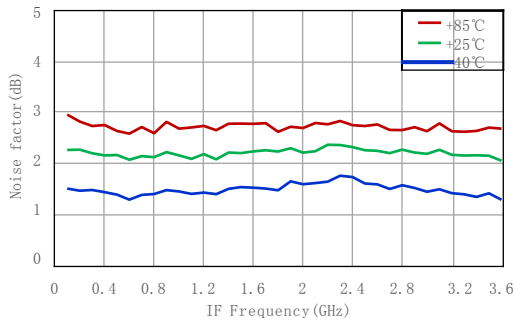

P1dB VS RF frequency (USB IF=0.5GHz power is 6dBm)

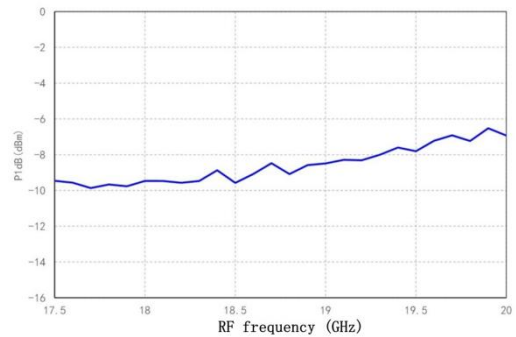

Test Curve

P1dB VS RF frequency (USB IF=3.3GHz power is 6dBm)

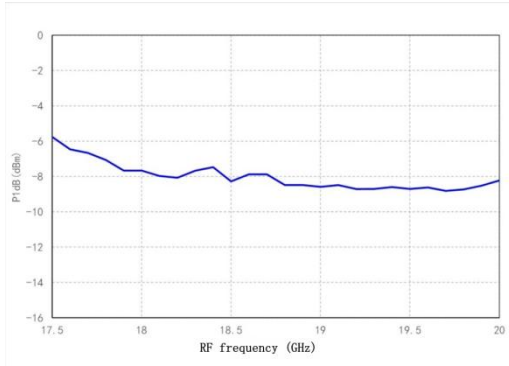

P1dB VS RF frequency (LSB IF=0.5GHz Power is 6dBm)

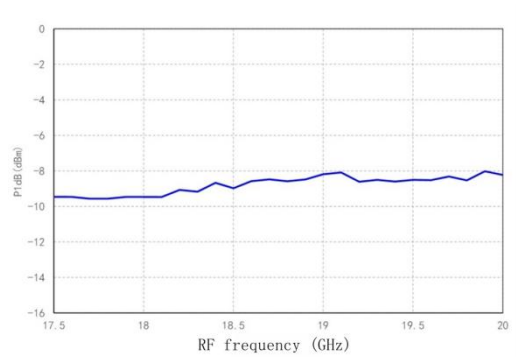

P1dB VS RF frequency (LSB IF=3.3GHz Power is 6dBm)

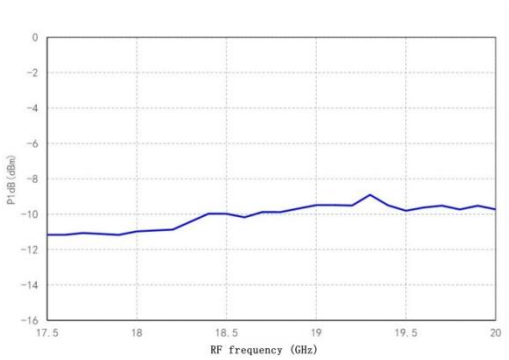

IP3 VS RF frequency (USB IF=1GHz power of 6dBm)

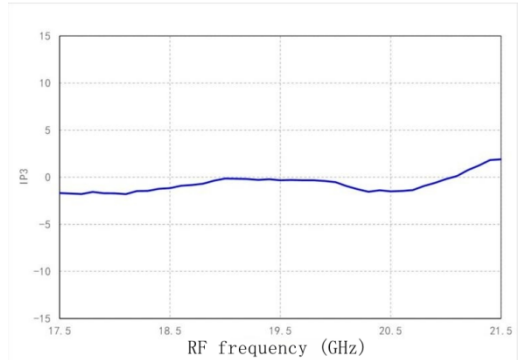

IP3 VS RF frequency (LSB IF=1GHz Power of 6dBm)

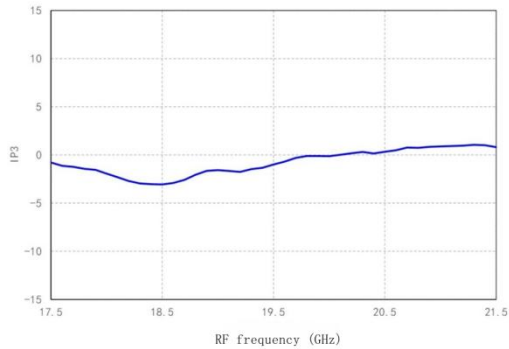

IP3 VS RF frequency (USB IF=3.3GHz power of 6dBm)

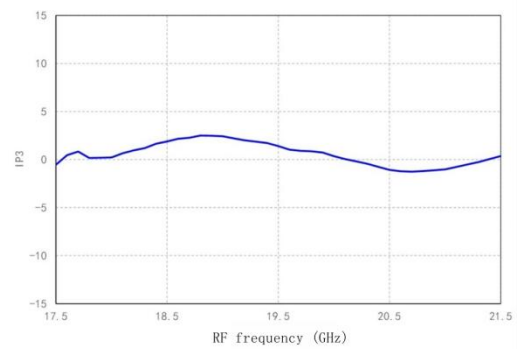

Test Curve

IP3 VS RF frequency (LSB IF=3.3GHz Power is 6dBm)

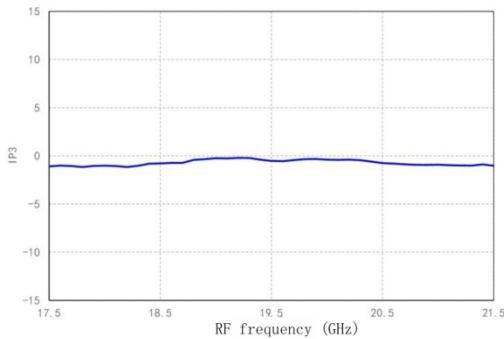

Stray -135;lower sideband;+25°C

		nLO					
mRF	0	1	2	3	4	5	
0	X	31.8	4.6	36.5	49.1	63.8	
1	17.9	32.9	0.0	30.9	38.8	54.2	
2	69.0	77.0	33.5	42.6	42.2	40.5	
3	X	88.9	77.0	72.0	50.0	54.2	
4	X	X	X	91.9	97.4	82.6	
5	X	X	X	X	X	87.7	

RF=18.0 GHz @ -15dBm

LO=9.735 GHz @ 6dBm

Stray -135;Upper sideband;+25°C

		nLO					
mRF	0	1	2	3	4	5	
0	X	23.5	2.5	41.9	41.0	68.0	
1	13.1	36.9	0.0	30.6	32.5	57.0	
2	52.9	75.4	42.5	51.7	33.2	60.2	
3	X	94.7	89.3	82.9	61.2	64.5	
4	X	X	X	89.0	91.1	89.8	
5	X	X	X	X	X	90.2	

RF=18.0 GHz @ -15dBm

LO=8.265 GHz @ 6dBm

Absolute maximum rating

RF/LO input power	10dBm
VDD	4V
Channel temperature	175° C
Storage temperature	-65°C~+150°C
Operating temperature	-55°C~+85°C

Working parameters

LO input power	2~6dB
VDRF/VDLO1/VDLO2	3.5v

Package Information

Model	Packaging Materials	Solder plate plating	MSL level [1]	Package identification [2]	Environmental requirements
CWDC264SP4	Green resin compounds	NiPdAuAg	MSL 3	S264X XXXX	RoHS compliant

[1] Maximum reflow temperature 260° C

[2] XXXXX is the lot number

Dimension

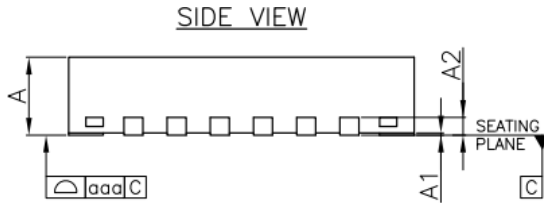
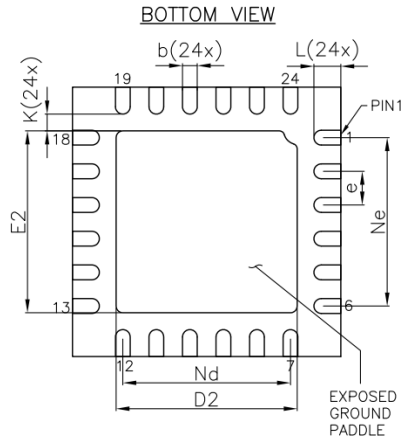
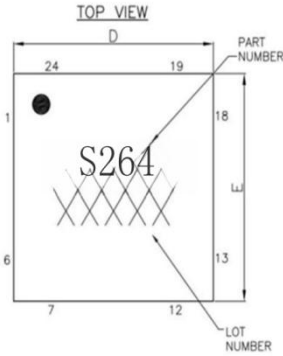

Symbol	MIN	NOM	MAX
A	0.70	0.75	0.80
A1	0.00	0.02	0.05
A2	0.20Ref		
b	0.18	0.25	0.30
D	3.90	4.00	4.10
D2	2.55	2.70	2.80
e	0.50BSC		
Ne	2.50BSC		
Nd	2.50BSC		
E	3.90	4.00	4.10
E2	2.55	2.70	2.80
K	0.20	---	---
L	0.30	0.40	0.50
aaa	0.08		

Description:

1. Unit: mm
2. Lead frame material: copper alloy
3. Package surface warpage: $\leq 0.05\text{mm}$
4. All ground pins should be connected to the PCB RF ground

Pin Definition

Pin Number	Function Symbols	Function Description	Pin Number	Function Symbols	Function Description
1	NC	Vacant	13	GND	RF Ground
2	NC	Vacant	14	IF1	IF output 1, DC coupling
3	VDRF	RF amplifier voltage	15	NC	Vacant
4	VDL2	Local amplifier voltage2	16	IF2	IF output 2, DC coupling
5	VDL1	Local oscillator amplifier voltage1	17	GND	RF Ground
6	NC	Vacant	18	NC	Vacant
7	NC	Vacant	19	NC	Vacant
8	LO	Local oscillator input, AC coupling	20	NC	Vacant
9	GND	RF Ground	21	NC	Vacant
10	NC	Vacant	22	NC	Vacant
11	NC	Vacant	23	RF	RF input, AC coupling
12	NC	Vacant	24	GND	RF Ground

Typical Applications

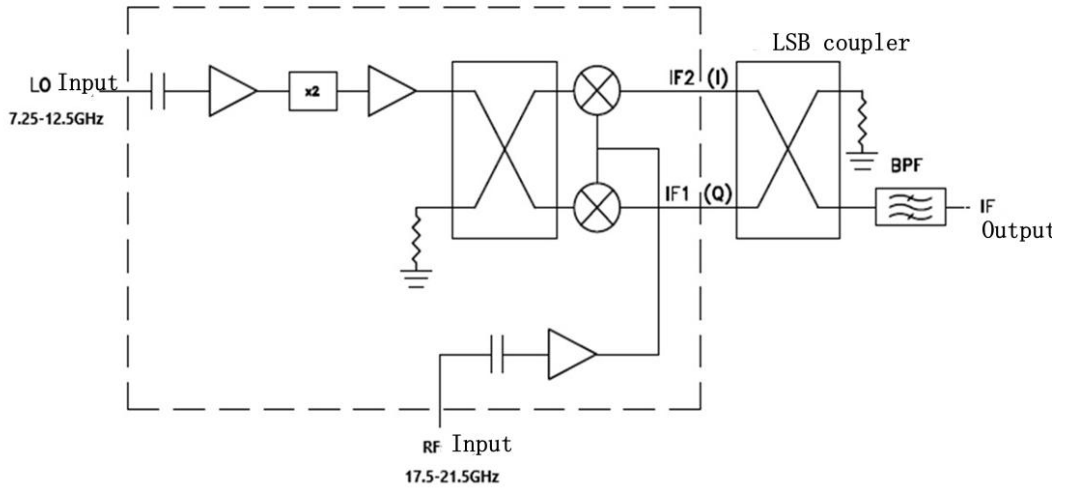

Evaluation Boards

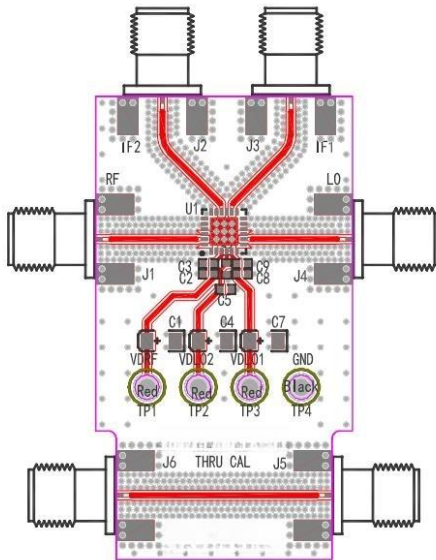
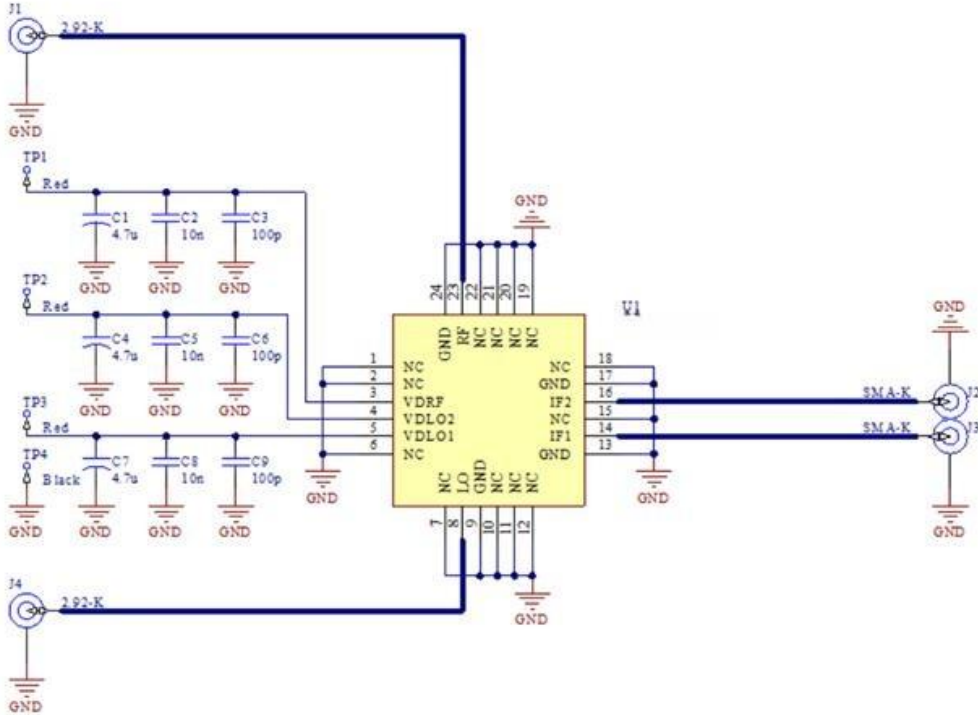

Designator	Description
C1,C4,C7	4.7uf Tantalum Capacitor 1206
C2,C5,C8	10nf Ceramic Capacitor 0402
C3,C6,C9	100pf Ceramic Capacitor 0402
TP4	Test point terminal red
TP1,TP2,TP3	Test point terminal black
J2,J3	SMA-K connector Nanjing Aowen D550B12E01-048
U1	CWDC264SP4
J1,J4,J5,J6 recommended to use 2.92-K connector	

Circuit board material: Rogers 4350B

The circuit board for the device application should be designed in accordance with the RF circuit design method and the signal

The grounding pin of the package housing should be grounded nearby (similar to the diagram), and there should be enough ground holes to connect the top and bottom ground.

Packaging Information

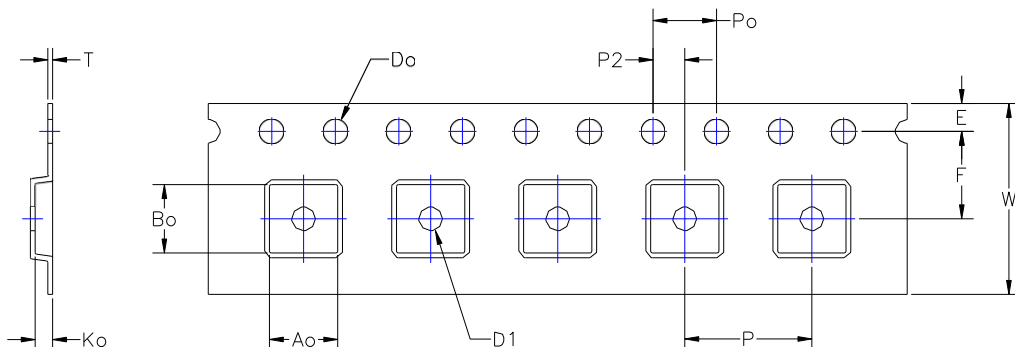

DIMENSION	SPEC
W	12.00 +/- 0.30
Do	∅1.50 +0.10/-0.00
Po	4.00 +/- 0.10
E	1.75 +/- 0.10
D1	∅1.50 MIN
Ao	4.30 +/- 0.10
Bo	4.30 +/- 0.10
P	8.00 +/- 0.10
P2	2.00 +/- 0.10
Ko	1.10 +/- 0.10
T	0.30 +/- 0.05
F	5.50 +/- 0.05

Orientation of the element in the carrier
(facing the carrier and the reel)

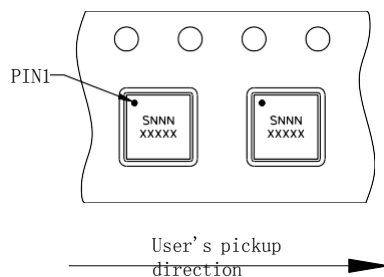

Description:

1. Unit: mm
2. Material: anti-static polyethylene
3. Color: Black
4. 10 positioning holes center distance (P0) cumulative tolerance ± 0.2

Reliability Testing - Wafer Verification

Test Project	Reference Standards	Test conditions	Sample size #lots/ss per lot	Number of accepted judgments (number of failures)
HTOL	JESD22-A108	TA=125°C, 2000hrs, bias VD1=VD2=3.5V	3lot/77units	0
		TA=125°C, 2000hrs, bias VD1=VD2=3.5V, shot Frequency excitation	3lots/11units	0
HTSL	JESD22-A103	TA=150°C, 1000hrs	3lot/25units	0
HAST	JESD22-A110	130°C, 85%RH, 96hours. Power per DUT<200mW	3lot/25units	0

Reliability Testing - Package Verification

Test Project	Reference Standards	Test conditions	Sample size #lots /ss per lot	Number of accepted judgments (number of failures)
Die shear	MIL883-M2019	Spec Limit (L) ≥ 0.50 (kg)	3lot/10units	0
Bond pull	MIL883-M2011	Spec Limit (L) ≥ 3.00 (g)	1lot/30bonds / 5 units	0
Bond shear	JESD22-B116A	Spec Limit (L) ≥ 8.10 (g)	1lot/30bonds /5 units	0
MSL or PC	J-STD-020	Per appropriate MSL level per J-STD-020 (MSL level 3)	3lot/25units	0
TC	JESD22-A104	-65°C~150°C, 500cycles	3lot/25units	0
Solderability	MIL883-M2003	245°C \pm 5°C, 5s \pm 0.5s	3lot/22leads	0
ESD-CDM	JSTD-002	All Pins Step:150V(+/-)	1lot/3units	0
ESD-HBM	JSTD-001	ALL_VSS TO VSS (+/-), ALL_VCC TO VCC (+/-), IO TO IO (+/-) Step:250V	1lot/3units	0

Cautions

- Attempts to clean the chip surface with wet chemical methods are prohibited.
- This product is an electrostatic sensitive device, so pay attention to anti-static when storing and using it.
- Storage in a dry cabinet at <30% humidity, 16-28° C ambient temperature.
- Please contact the supplier if you have any questions.