

### Performance Features

- Conversion loss: 8.5dB
- LO to RF isolation: 55dB
- LO to IF isolation: 35dB
- Passive double balanced topology
- Wide IF bandwidth: DC~2GHz
- Package size: 3mm\*3mm 12-pin QFN

### Overview

The CWM8002SP3B is a general-purpose, double-balanced mixer manufactured in a GaAs process. It is a passive device that requires no bias, external components or matching circuitry. It can be used as an upconverter or downconverter from 1.8 GHz to 6 GHz.

### Typical Applications

- Point-to-Point Communication
- Instrumentation
- 5G Communication

### Functional Block Diagram

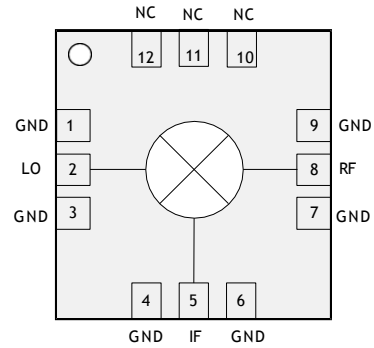

### Electrical performance table (TA=+25°C)

Parameter Name	Description	Minimum value	Typical values	Maximum value	Unit
RF Frequency	RF, LO port	1.8~6			GHz
IF frequency	IF Port	DC~2			GHz
Conversion loss			8.5	10	dB
Noise factor	SSB		8.5	10	dB
Isolation degree	LO to RF port		55		dB
	LO to IF port		35		dB
	RF to IF port		25		dB
Input 1dB compression point			12		dB
Enter IP3			20.5		dBm

### Test Curve

IF gain vs. RF frequency (upconversion)

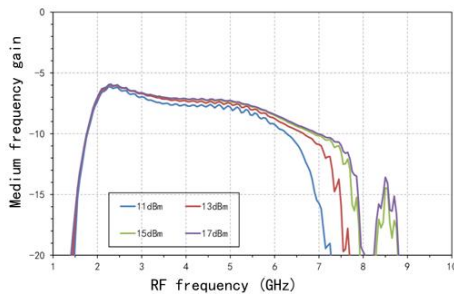

IF gain vs. RF frequency (down conversion)

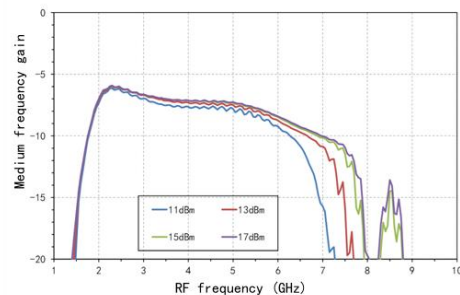

### Test Curve

Isolation vs. frequency

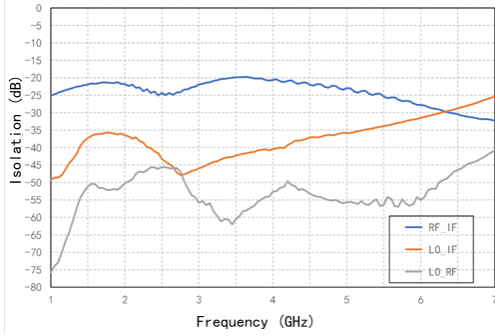

Downconversion IP3 VS RF frequency (high fundamental oscillation)

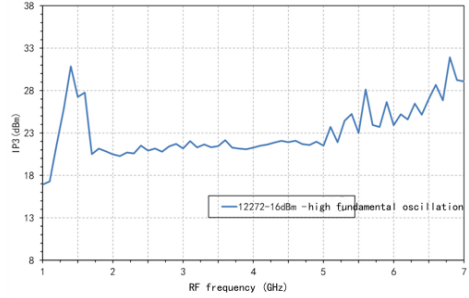

RF return loss vs. frequency (@LO=11, 13, 15, 17dBm)

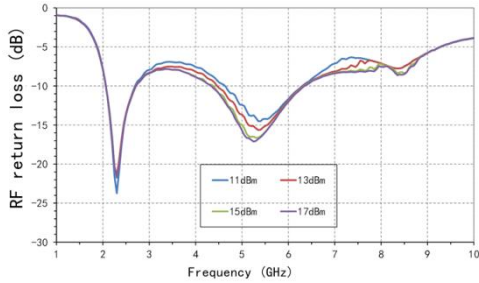

IF Return Loss VS Frequency (@LO=11, 13, 15, 17dBm LO=4.5GHz)

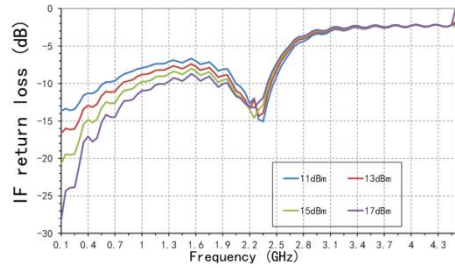

Return Loss vs. Frequency (@LO=15dBm)

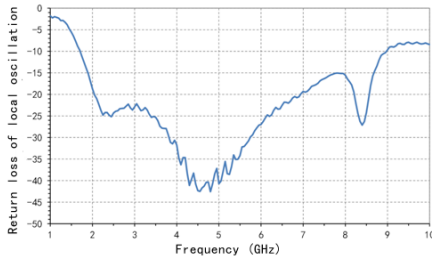

### Working parameters

Operating temperature	-40°C~+85°C
-----------------------	-------------

### Absolute maximum rating

RF input power	25dBm
LO input power	25dBm
Storage temperature	-65°C~+150°C
ESD (HBM)	TBD

### Package Information

Model	Packaging Materials	Solder plate plating	MSL level <sup>[1]</sup>	Package identification <sup>[2]</sup>	Environmental requirements
CWM8002SP3B	Green resin compounds	Sn	MSL 3	S8002 XXXXX	RoHS compliant

<sup>[1]</sup> Maximum reflow temperature 260° C

<sup>[2]</sup> XXXXX is the lot number

### Dimension

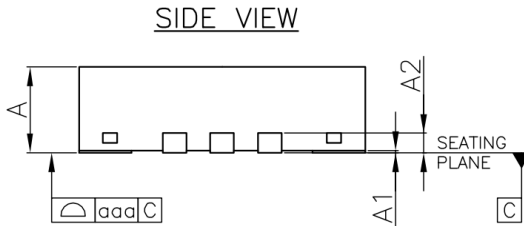
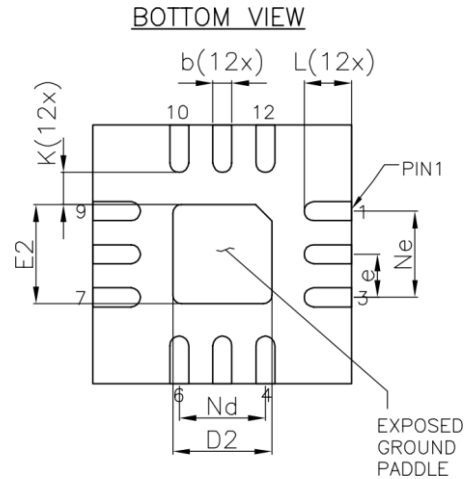
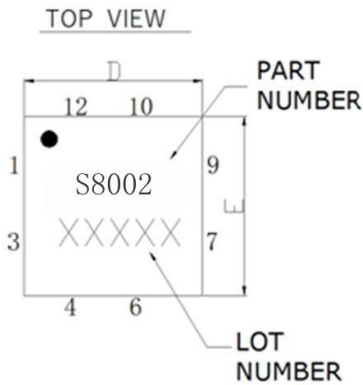

Description:

1. Unit: mm
2. Lead frame material: copper alloy
3. Package surface warpage:  $\leq 0.05\text{mm}$
4. All ground pins should be connected to PCB RF ground

Symbol	MIN	NOM	MAX
A	0.70	0.75	0.80
A1	0.00	0.02	0.05
A2	0.20Ref		
b	0.17	0.22	0.27
D	2.90	3.00	3.10
D2	1.05	1.15	1.25
e	0.50BSC		
Ne	1.00BSC		
Nd	1.00BSC		
E	2.90	3.00	3.10
E2	1.05	1.15	1.25
K	0.20	---	---
L	0.40	0.50	0.60
aaa	0.08		

### Pin Definition

Pin Number	Function Symbols	Function Description	Pin Number	Function Symbols	Function Description
1	GND	RF Ground	7	GND	RF Ground
2	LO	Local oscillator input	8	RF	RF input
3	GND	RF Ground	9	GND	RF Ground
4	GND	RF Ground	10	NC	Vacant
5	IF	Medium Frequency Output	11	NC	Vacant
6	GND	RF Ground	12	NC	Vacant

### Evaluation Boards

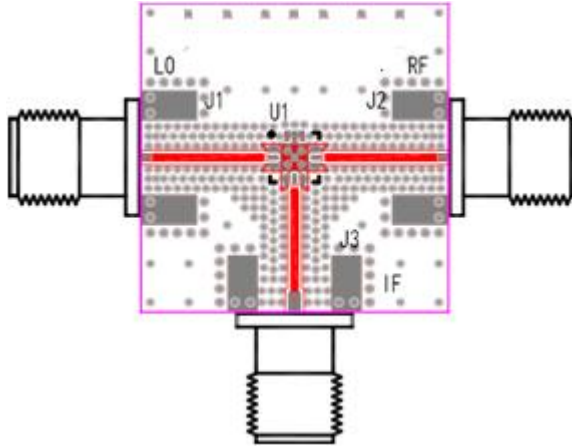
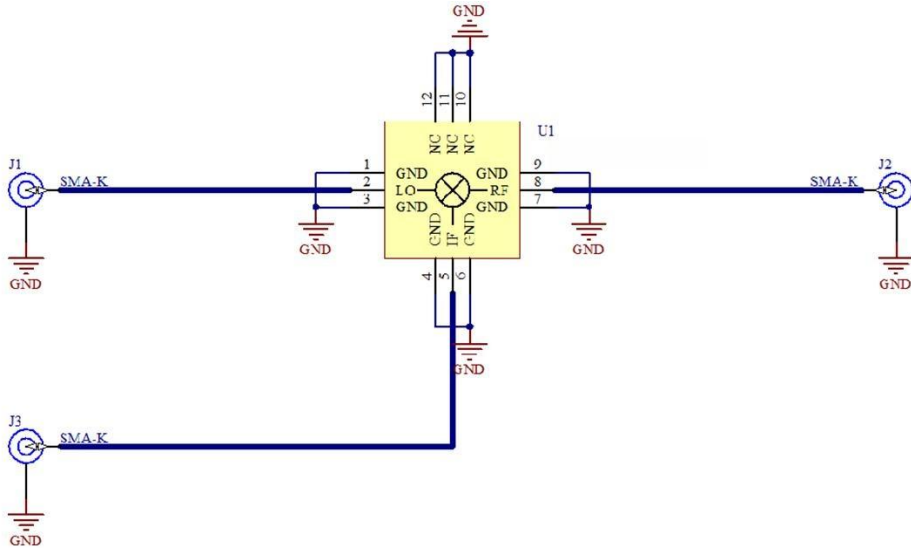

Circuit board material: Rogers 4350B

The circuit board of the device application should be designed according to the RF circuit design method, the signal line should be designed according to the 50 ohm impedance, and the ground pin of the package shell should be grounded nearby (similar to the figure), and there should be enough grounding holes to connect the top and bottom ground layers.

Designator	Description
J1, J2, J3	SMA-K connector Nanjing Aowen D550B12E01-048
U1	CWM8002SP3B
J1, J2, J3 are recommended to use Nanjing Aowen D550B12E01-048 SMA connector	