

Performance Characteristics

- Wide bandwidth: 2GHz~22GHz
- Low noise: 2dB typical
- Small Signal Gain: 14dB typical
- Output P1dB: 14dBm typical
- Output IP3: 25dBm typical
- Package size: 5mm*5mm

typical application

- point-to-point communication
- point-to-multipoint communication
- Instrumentation

functional block diagram

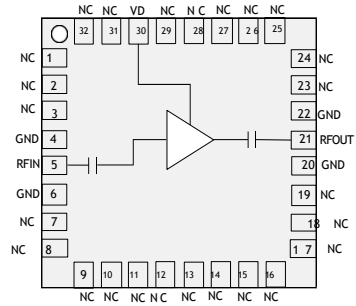

summarize

The CWA462SP5 is a 2GHz to 22GHz low noise broadband amplifier fabricated in GaAs process. The amplifier is self-biased with 50Ω matched loads at the input and output.

Electrical performance table (T_A = +25°C)

Parameter name	descriptive	minimum value	typical value	maximum values	unit (of measure)
operating frequency		2~22			GHz
gain (electronics)			14		dB
Gain Flatness			±0.7		dB
Input Return Loss			10		dB
Output Return Loss			14		dB
Output power 1dB compression point			14		dBm
Output IP3			25		dBm
coefficient of noise			2		dB
Operating Current			58		mA
operating voltage	VD	4.75	5	5.25	V

Test curve (VD=5V, ID=58mA)

Small Signal Response (25°C)

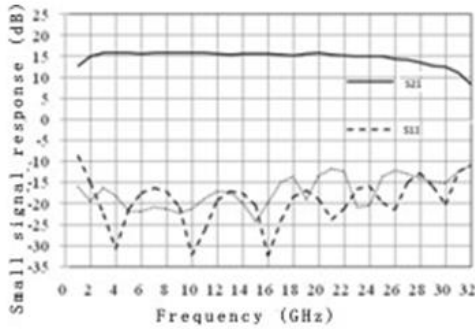

Gain Vs Temperature

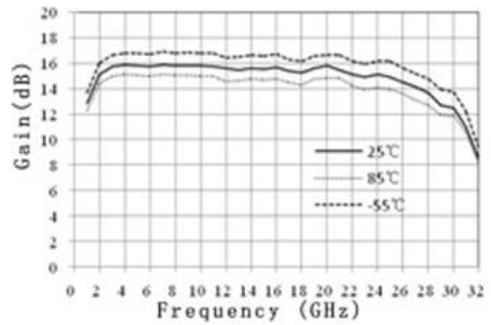

Noise factor Vs temperature

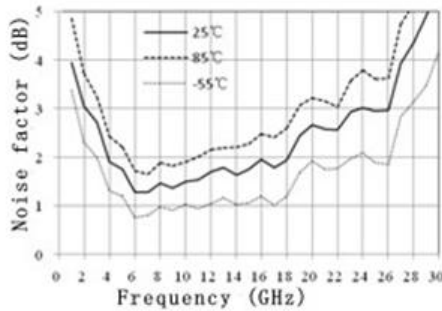

Output 1dB compression point Vs temperature

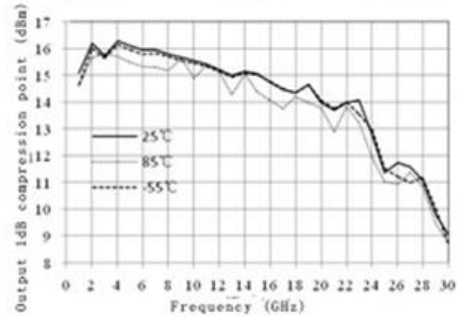

Output saturation power Vs Temperature

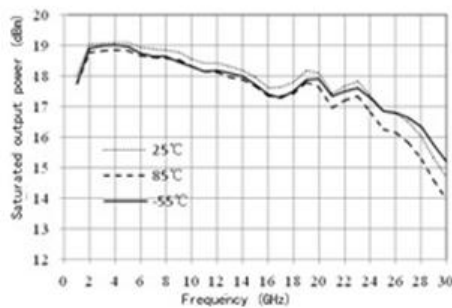

Output third-order intermodulation point (25°C)

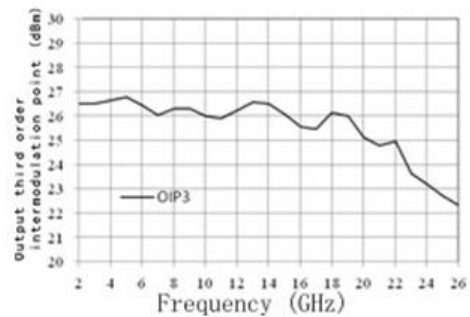

Operating parameters

operating temperature	-40°C~+85°C
Leakage Voltage v_D	4.75V~5.25V
electric current I_D	58mA

Absolute maximum rating

Storage temperature	-65°C~+150°C
Leakage Voltage V_D	9V
ESD-HBM	TBD

Package Information

model number	package material	Pad plating	MSL rating (1)	Package identification (2)	environmental requirement
CWA462SP5	Green resin compounds	NiPdAuAg	MSL 3	CWA462XX XXX	RoHS compliant

(1) Maximum reflow temperature 260° C

(2) XXXXX is the lot number

Overall dimensions

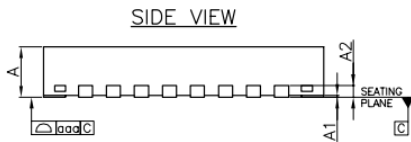
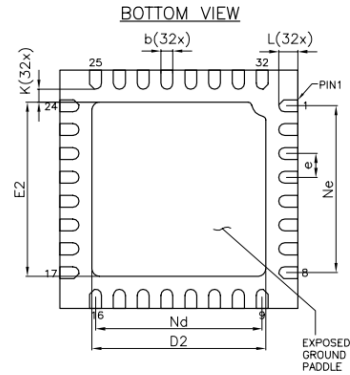
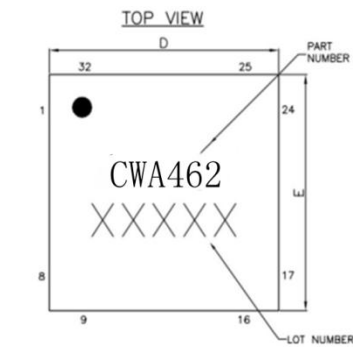

Dimension Table (unit:mm)			
Symbol	MIN	NOM	MAX
A	0.70	0.75	0.80
A1	0.00	0.02	0.05
A2	0.20Ref		
b	0.18	0.25	0.30
D	4.90	5.00	5.10
D2	3.50	3.65	3.75
e	0.50BSC		
Ne	3.50BSC		
Nd	3.50BSC		
E	4.90	5.00	5.10
E2	3.50	3.65	3.75
K	0.20	---	---
L	0.30	0.40	0.50
aaa	0.08		

Description:

- Unit: mm
- Lead frame material: copper alloy
- Package surface warpage: no more than 0.05mm
- All ground pins should be connected to PCB RF ground.

Pin Definitions

Pin Number	functional symbol	Functional Description	Pin Number	functional symbol	Functional Description
1	NC	let sth. lie idle	17	NC	let sth. lie idle
2	NC	let sth. lie idle	18	NC	let sth. lie idle
3	NC	let sth. lie idle	19	NC	let sth. lie idle
4	GND	radio-frequency zone	20	GND	radio-frequency zone
5	RFIN	RF input	21	RFOUT	RF output
6	GND	radio-frequency zone	22	GND	radio-frequency zone
7	NC	let sth. lie idle	23	NC	let sth. lie idle
8	NC	let sth. lie idle	24	NC	let sth. lie idle
9	NC	let sth. lie idle	25	NC	let sth. lie idle
10	NC	let sth. lie idle	26	NC	let sth. lie idle
11	NC	let sth. lie idle	27	NC	let sth. lie idle
12	NC	let sth. lie idle	28	NC	let sth. lie idle
13	NC	let sth. lie idle	29	NC	let sth. lie idle
14	NC	let sth. lie idle	30	VD	leakage
15	NC	let sth. lie idle	31	NC	let sth. lie idle
16	NC	let sth. lie idle	32	NC	let sth. lie idle

evaluation board

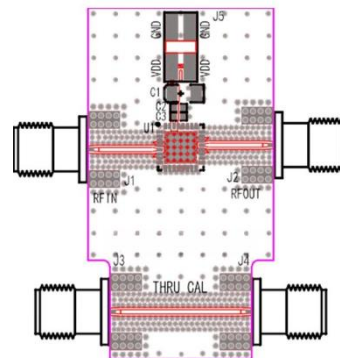
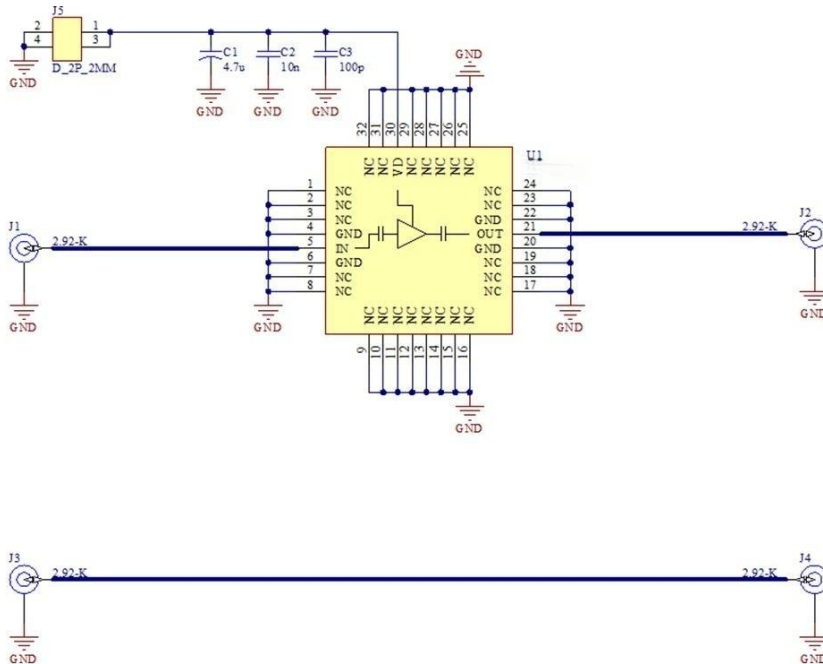

Circuit Board:Rogers4350B

The circuit board of the device application should be designed according to the design method of RF circuit, the signal line is designed according to 50 ohm impedance, and the ground pin of the package shell should be grounded nearby (similar to that in the figure), and there should be enough ground holes for connecting the top layer to the bottom layer grounding ground.

Designator	Description
C1	4.7uF Tantalum Capacitor 1206
C2	10nF Multilayer Ceramic Capacitors 0402
C3	100pF Multilayer Ceramic Capacitors 0402
J1, J2, J3, J4	SMA-K connector Nanjing Aowen D360B12E01-023
J5	D_2P_2MM DC Pin
U1	CWA462SP5